



Haze Battery Company Ltd



**Sealed Lead Acid 6 & 12 Volt
Monobloc
AGM Range**

CONSTRUCTION - AGM battery construction is as shown in the diagram below. The positive and negative grids are cast from a calcium / tin lead alloy to reduce grid growth and corrosion. The active material is manufactured from high purity lead (99.9999%) to minimise the negative effects of impurities.

Separator is a mat of random woven acid resistant glass fibres, which acts as a sponge - soaking up and immobilising the electrolyte whilst maintaining good acid to plate contact and availability during discharge. "S wrapping" is employed to eliminate the risk of short circuits due to mossing and debris at the bottom of the cell.

The purpose of the separator is to maintain a constant distance between the positive and negative plates, thus removing the possibility of short circuits whilst allowing the active material to fully react with the electrolyte. The random weaving also results in an open structure, which offers minimal resistance to the flow of electrolyte during filling.

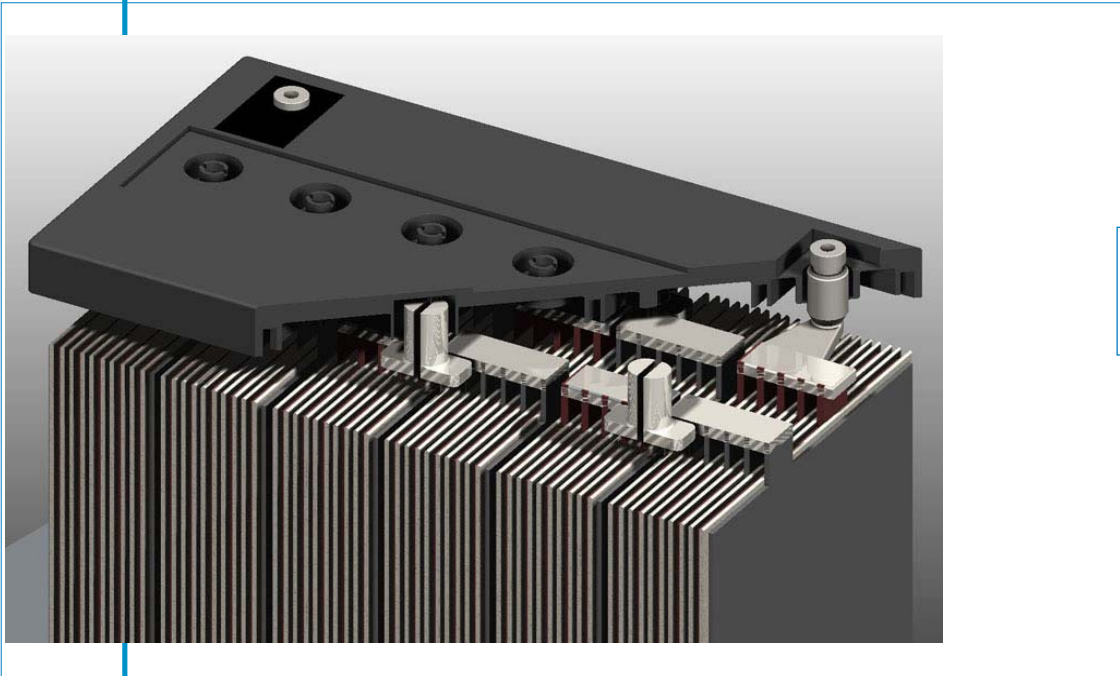

AGM construction with case removed and cover cut away to show internal battery parts.

ELECTROLYTE FILLING - Special production and QC systems are utilised to ensure the electrolyte saturation is optimised for each battery. The battery design and construction negates the need for electrolyte addition and the battery remains maintenance free throughout its design life.

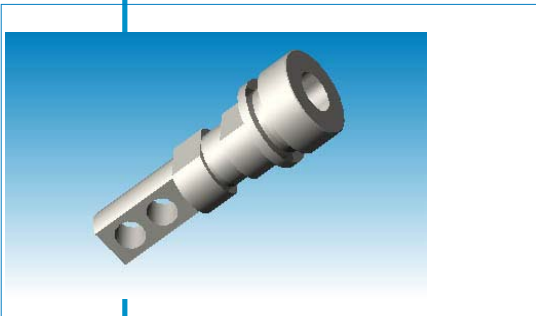

SAFETY RELEASE VALVE- The battery will operate above atmospheric pressure under normal operating conditions, however the maximum pressure is governed by the safety release valve. Open is activated by pressures in excess of approx. 2 psi (14 Kpa), resealing at approx 1.2 psi (8.4 Kpa).

GAS RECOMBINATION - The gasses generated during normal operation of the battery are internally recombined. In fact more than 99% of the gas achieves recombination.

TERMINAL CONSTRUCTION - The contact quality between the insert terminal and the lead post is of vital importance during short duration / high Amp discharges. Elevated terminal temperatures are the result of poor contact, eventually causing seal degradation and electrolyte leaks. Haze design and assembly technique for terminal casting ensures trouble free operation for the design life of the battery.

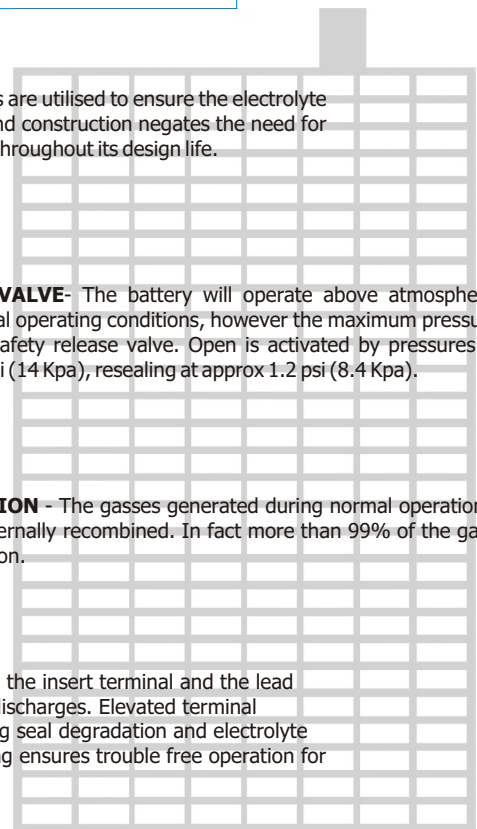

AGM Vs Gel

Each battery has advantages and disadvantages, it is therefore important to choose the right battery for the application.

Advantages of AGM Batteries:

- Lower initial cost when compared to Gelled Electrolyte cells.
- Ideal for starting and stationary applications.
- Superior performance for shorter duration / higher current discharges.
- Smaller size battery can be used for higher rate discharges.



Applications

- Float service
- Uninterruptible Power Supplies
- Medical
- Telecommunications
- Switch Gear
- Photovoltaic
- Solar
- Wind
- Control Systems
- Cellular Radio Stations
- Cathodic Protection
- Navigation Aids
- Marine equipment
- Electric Power Systems

Capacity temperature correction Factor to be applied to Data at 20 Degrees C

Discharge Time	-30 °C	-20 °C	-10 °C	0 °C	5 °C	10 °C	15 °C	20 °C	25 °C	30 °C	35 °C	40 °C	50 °C
5 minutes to 59 minutes	0.23	0.417	0.605	0.778	0.86	0.91	0.96	1	1.037	1.063	1.085	1.1	1.116
1 Hour to 100 Hours	0.277	0.464	0.647	0.816	0.886	0.93	0.97	1	1.028	1.05	1.063	1.07	1.078

CHEMICAL REACTION- The chemical reaction for the Discharge / Recharge process is represented by the following formula:

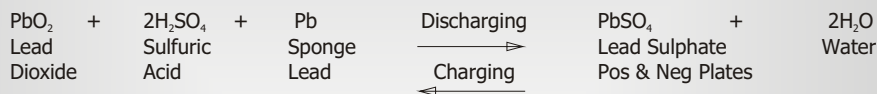

Under normal float charge conditions the oxygen passes through the separator from the positive to the negative plate where it reacts with the negative active material to form lead oxide.

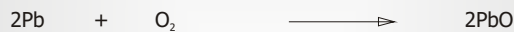

In the acid conditions the lead oxide reacts with the sulfuric acid to form lead sulphate.

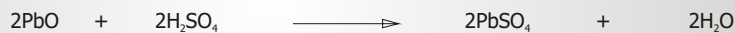

The lead sulphate formed on the negative is then reduced to lead and sulfuric acid by the evolving hydrogen.

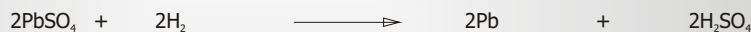

If the equations are resolved and like terms cancelled out on both sides of the equation the result is:

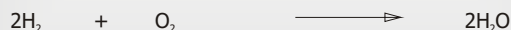

This reaction summarises what is meant by GAS RECOMBINATION. The process can never be 100% efficient, normal recombination efficiency is 95 - 99%.

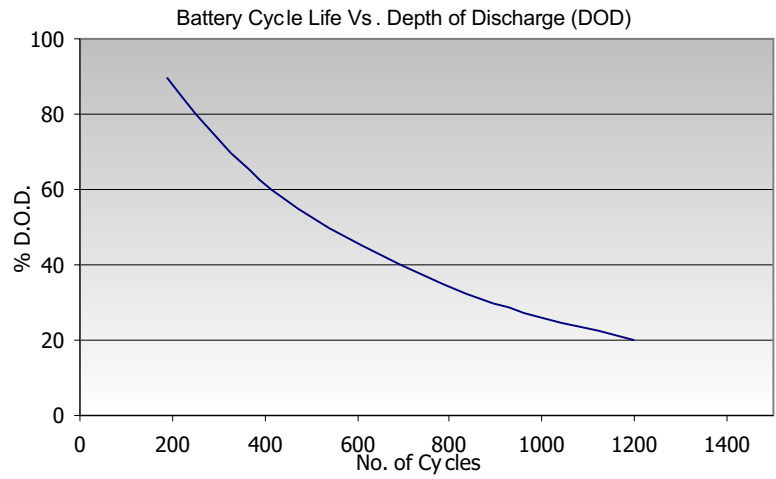

Innovative Features

- Completely maintenance free, sealed construction eliminates the need for watering
- Increased durability and deep cycle ability for heavy demand applications
- Special formation process
- Analytical Grade electrolyte
- Spill proof / leak proof
- Valve regulated Max internal pressure 2.5 psi
- Multi-position usage
- ABS Case and cover - VO on request
- Low self discharge
- FAA and IATA approved as non-hazardous
- Built to comply with IEC 896-2, DIN 43534, BS 6290 Pt4, Eurobat.

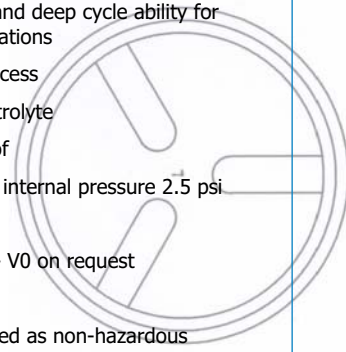

Specifications

Nominal Voltage	6 & 12 Volts
Design Life	12 Years @ 20 °C
Operating Temperature	-10 °C to 45 °C
Grid alloy	Calcium / Tin lead alloy
Plates	Flat Pasted
Separator	Absorbant Glass Mat
Active material	Very high purity lead
Case and cover	ABS (VO on request)
Charge Voltage	Float 2.27 - 2.30 VPC @20 °C Cycling 2.40 @20 °C
Electrolyte	Max. 2.4 VPC Max ripple 3.5%
Venting Valve	Charging V
Terminal	Sulphuric acid Analytical grade purity
Torque setting	EPDM Rubber 1.5 to 2 psi (10.5 - 14 KPa) release pressure. Resealing at 1 psi (7 KPa)
Cables	Various types Epoxy sealed by extended mechanical paths
	The recommended torque value for all types is 5-7 Nm
	Insulated cables / connectors supplied on request.

Haze Battery Company keenly encourages environmental awareness; PLEASE follow guidelines for the recycling /disposal of lead.

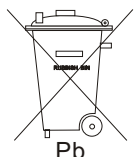
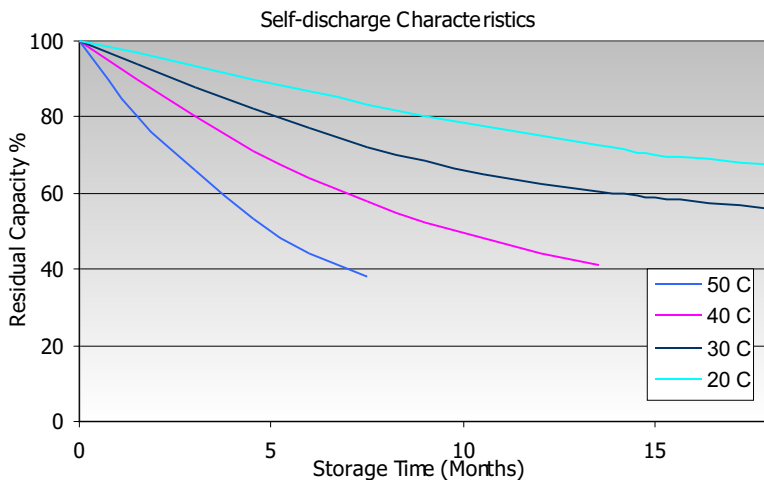

Relationship Between Charge Voltage and Temperature

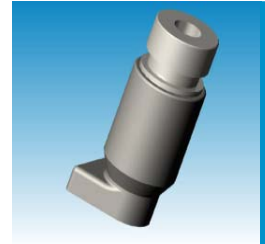
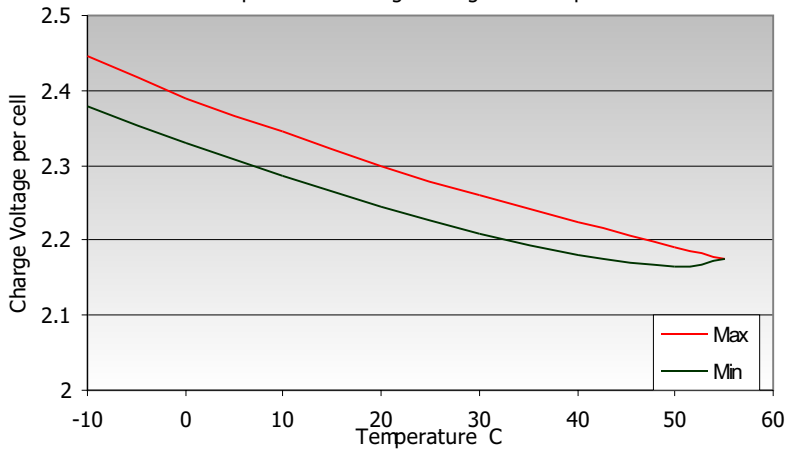

Capacity Vs Ambient Temperature

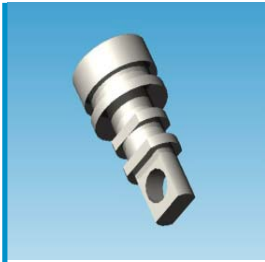
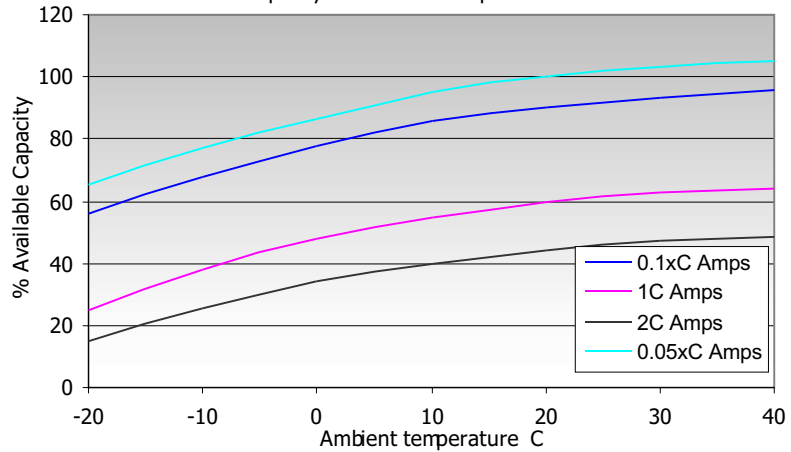

CHARGING CHARACTERISTICS

Floating - The optimum float voltage for a battery is temperature dependant, at 15 - 24°C the recommended value is 2.27 - 2.30V. It is recommended that battery installation sites are temperature controlled, however float voltage can be increased or decreased to compensate for temperature variations. Adjustment is calculated at +/- 3 mV per degree C.

Operating Temperature	Recommended Applied Float Voltage VPC
0-9	2.33 - 2.35
10-14	2.30 - 2.33
15-19	2.27 - 2.30
20-24	2.27 - 2.30
25-29	2.25 - 2.27
30-34	2.23 - 2.25
35-40	2.21 - 2.23

Terminal Options (left to right)

- ▶ Lead Flag
- ▶ Automotive
- ▶ J Type
- ▶ Copper Flag
- ▶ J Type Adapter
- ▶ Insert

Insert are made from brass with copper, nickel and silver plating giving excellent mechanical, electrical and corrosion resistant properties.

The most suitable charging method for battery life and performance is the constant voltage method with a limited initial current, usually limited to a maximum of $C_{20}/4$.

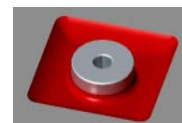
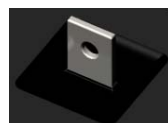
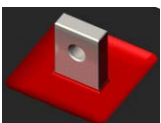



Central Gassing - Haze produce some models with a integral central gassing system. This system is a useful feature when batteries are installed in an IP66 cabinet. Sealing prevents any escaping gas from exiting the enclosure. Central gassing allows a tube carrying the emissions to pass through a seal to atmosphere.

Haze are adding this feature to a number of sizes, if you require this feature please contact us for an up-to-date list of models included.

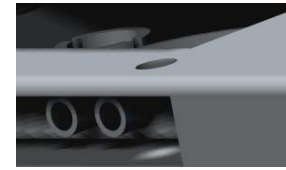

Battery Model	Qty Per Box	Dimensions (mm) & weight (kg)				Dimensions (Inches) & weight (lbs)				Terminal Layout	BCI Group Size	Internal Resistance mOhms	Conductance Values +/- 25%	Maximum Charge Current	CCA at 0 °C	Short Circuit Amps
		Length	Width	Height	Weight	Length	Width	Height	Weight							
HZB12-18	2	181	76	167	5.45	7.13	2.99	6.57	12.0	C - M5	-	11	400	4.5	270	732
HZB12-26	1	178	168	124	8	7.01	6.61	4.88	17.7	C - M5	-	6.5	420	6.5	300	900
HZB12-28	1	166	125	175	9	6.54	4.92	6.89	19.9	C - M5	-	7	450	7	305	910
HZB12-33	1	195	130	160	10.4	7.68	5.12	6.30	23.0	B - M6	U1	7	500	8	320	1100
HZB12-44	1	198	167	157	13.3	7.80	6.57	6.18	29.4	C - M6	-	6.2	670	11	350	1400
HZB12-55	1	229	138	213	17	9.02	5.43	8.39	37.6	B - M6	22NF	6.5	600	14	380	1700
HZB12-60	1	228	139	217	18.6	8.98	5.47	8.54	41.1	B - M6	-	5.7	680	15	410	1750
HZB12-70J	1	349	168	175	21	13.74	6.61	6.89	46.4	C - M6	-	5	900	18	550	2100
HZB12-70	1	260	168	211	24.3	10.24	6.61	8.31	53.7	B - M6	24	5	1000	18	550	2100
HZB12-80	1	260	168	211	25.8	10.24	6.61	8.31	57.0	B - M6	24	5	1150	20	620	2400
HZB12-90	1	306	168	211	30.1	12.05	6.61	8.31	66.5	B - M6	27	4	900	22	680	2650
HZB12-100	1	306	168	211	28.8	12.05	6.61	8.31	63.6	B - M6	27	4	1300	25	780	2900
HZB12-110	1	329	173	209	32.5	12.95	6.81	8.23	71.8	B - M6	31	4	1200	27	960	3000
HZB12-115	1	349	174	216.5	37.7	13.74	6.85	8.52	83.3	B - M6	-	3.6	1230	28.5	980	3100
HZB12-120	1	408	176	227	35.8	16.06	6.93	8.94	79.1	B - M6	-	3	1250	30	1020	3300
HZB12-135	1	340	173	283	40.6	13.39	6.81	11.14	89.7	B - M6	-	2.73	1300	35	1160	3750
HZB12-150	1	482	170	242	44	18.98	6.69	9.53	97.2	B - M6	-	2.5	1300	38	1300	4200
HZB12-160	1	530	209	214	55	20.87	8.23	8.43	121.6	E - M6	4D	2	1750	40	1440	4700
HZB12-200	1	520	240	220	60.9	20.47	9.45	8.66	134.6	E - M8	-	<2	2050	50	1670	5400
HZB12-230	1	521	269	203	74	20.51	10.59	7.99	163.5	E - M8	8D	<2	2150	57	1870	5900
HZB6-110	1	193	168	205	17.9	7.60	6.61	8.07	39.6	A - M6	-	4	1300	27	1010	3200
HZB6-160	1	298	171	226	26.4	11.73	6.73	8.90	58.3	A - M6	-	2	1500	40	1290	4600
HZB6-200	1	323	178	225	31.8	12.72	7.01	8.86	70.3	A - M8	-	<2	2050	50	1600	5000

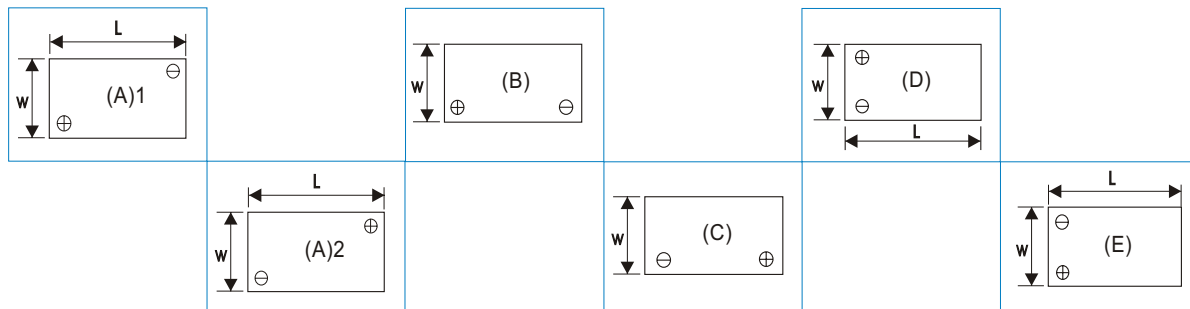

Terminal Layout details

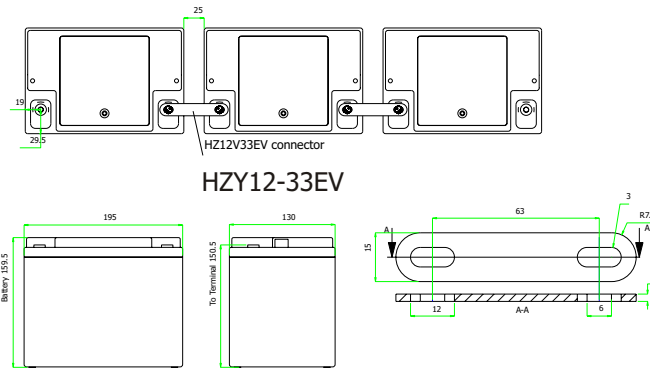

Battery installations have many variables : space available, autonomy times, load carrying requirements etc.

Haze Engineering department is at the customers disposal to find the best solution, provide dimensioned layout drawings and wiring diagrams.

A tailor made solution to meet the customers requirements.

All drawings are submitted for customer approval to ensure trouble free installation.

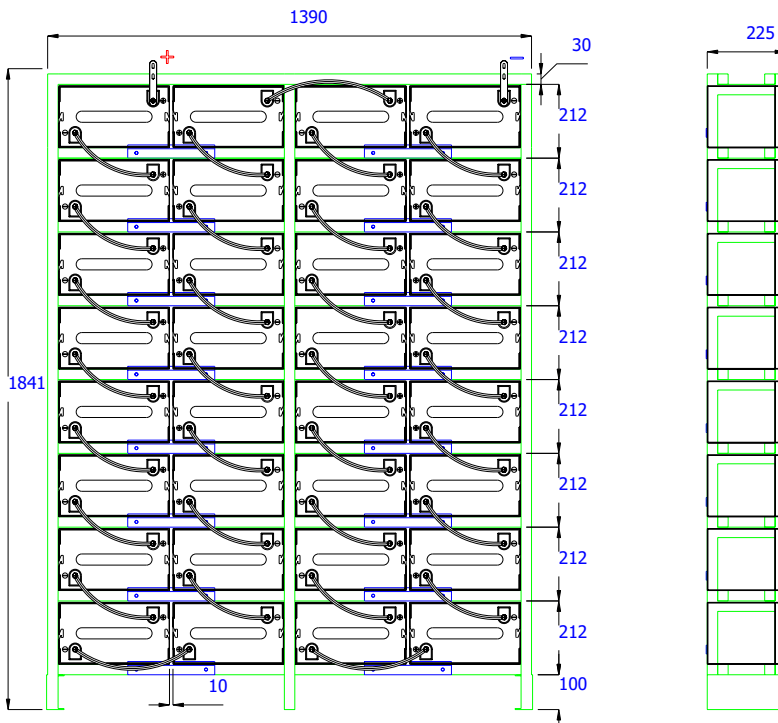
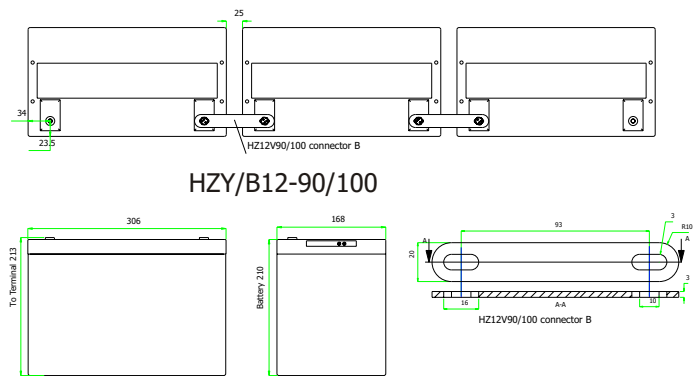

Racking is available to suit available space and required configuration.

Special cables and / or standard connectors can be provided on request along with wiring diagrams.

A range of terminal covers are available to cover large and small batteries and cables or connectors.

The example rack shown is for HZB/Y6-200.



210307

VRLA Product Range

4, 6 & 12 Volt AGM 1.3 to 230AH

6 & 12 Volt Gel 7.5 to 230AH

12 Volt Front Access AGM

12 Volt Front Access Gel

2 Volt AGM & Gel 50 to 3850AH

EV Gel

EV AGM

Marine Gel

Solar